

Existing Ground Floor Plan

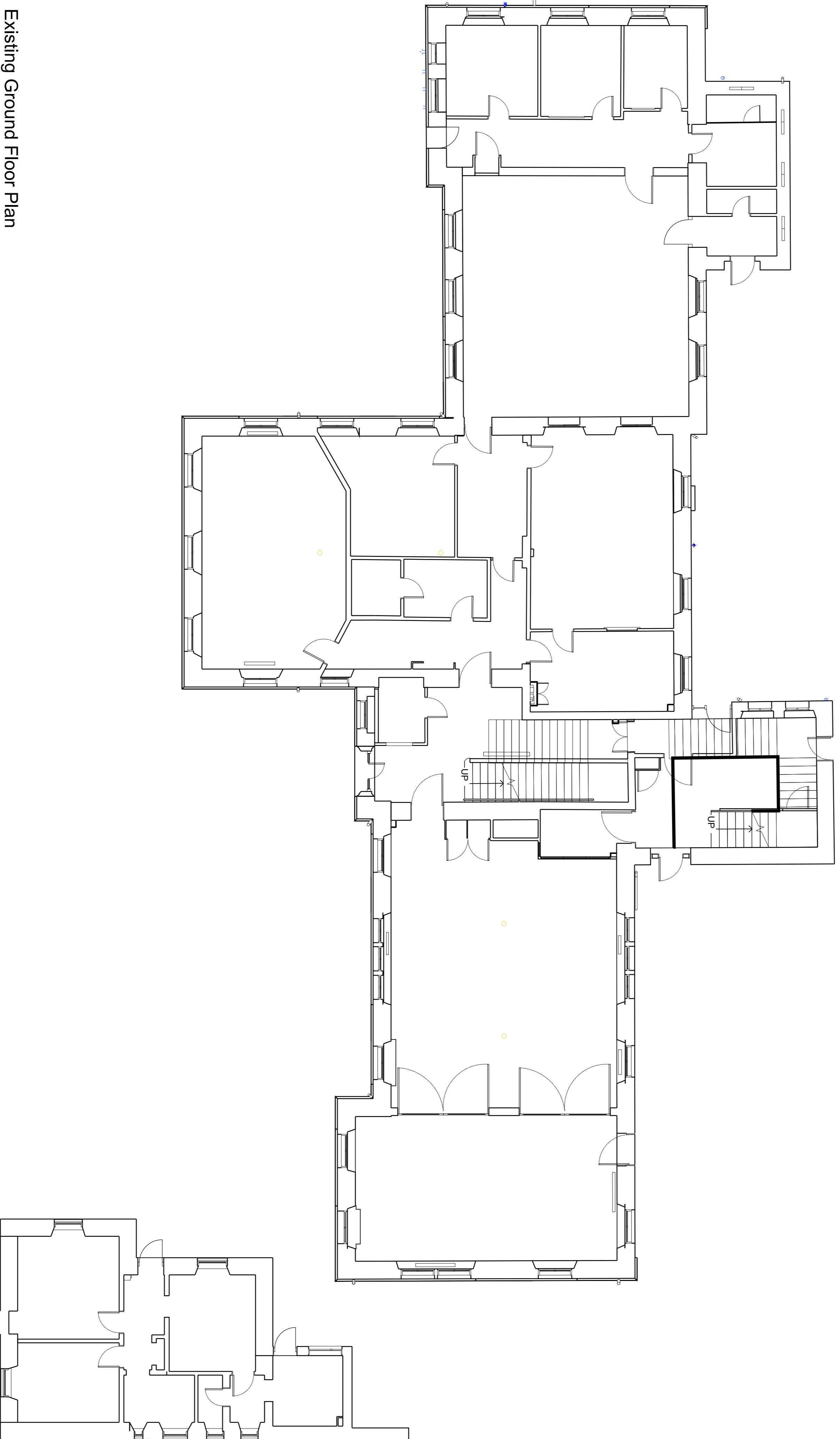

DO NOT SCALE

Drawings printed from pdf files must be checked against scale bar for accuracy.
 The Contractor must check & verify all sizes & locations of openings, levels & levels in the drawings at OCA's works commencing work.
 The Drawing must be read with the RB's Contract Specification and any amendments to the Contract Specification.
 The Contractor must check the drawings with the RB's Contract Specification and any amendments to the Contract Specification.
 The Contractor must check the drawings with the RB's Contract Specification and any amendments to the Contract Specification.

INFORMATION

Country: St Regeneration

Whalley Group

Existing Ground Floor

1250	AL(0)101	-	-
1000	AT	250x118	

anderson bell + christie architects

362 Great Western Road
 Glasgow G4 8HT
 T: +44 (0)141 339 1515
 E: andbell@andbell.co.uk
 W: www.andbell.co.uk

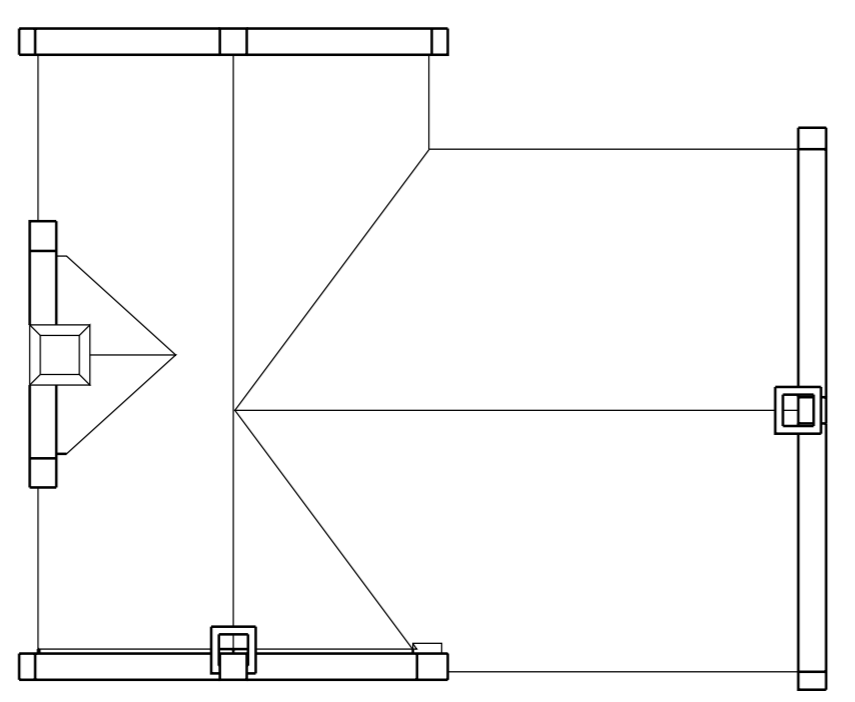
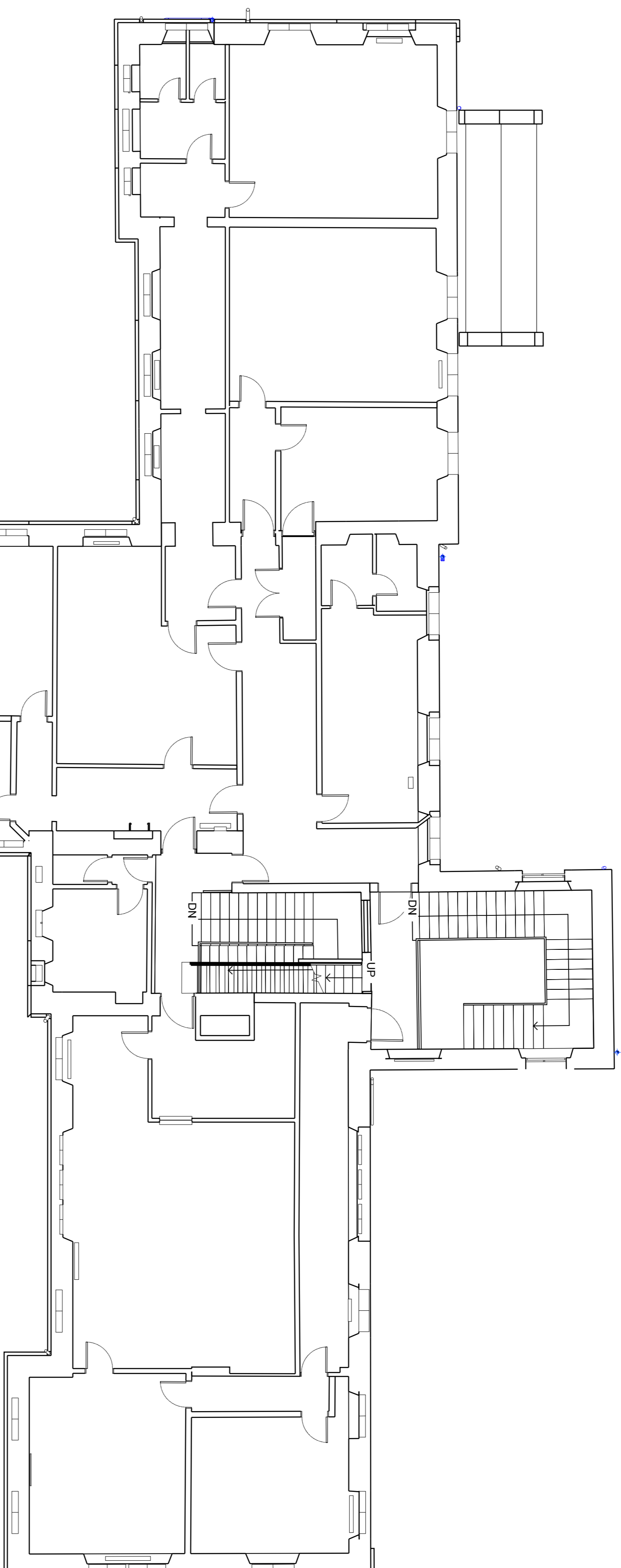

Existing First Floor Plan

When printing from PDF this line should measure 50mm

DO NOT SCALE

Changes printed from pdf files must be checked against scale bar for accuracy.

The Contractor must check & verify all sizes & locations of services, levels & levels before starting work.

The Drawing must be read with the RIBS Contract Specification and any amendments.

Notes on drawings are to be read in conjunction with the RIBS Contract Specification and any amendments.

It is the Contractor's responsibility to ensure that the drawings are read in conjunction with the RIBS Contract Specification and any amendments.

INFORMATION

Country: St Regeneration

Whalley Group

Existing First Floor

1250 AL(0)102

1:100 A1 250x118

250x118

250x118

250x118

250x118

250x118

anderson bell + christie
architects

362 Great Western Road
Glasgow G4 8RT
T: +44 (0)141 339 1515
E: info@abdcr.com
W: www.andersonbellchristie.com

250x118

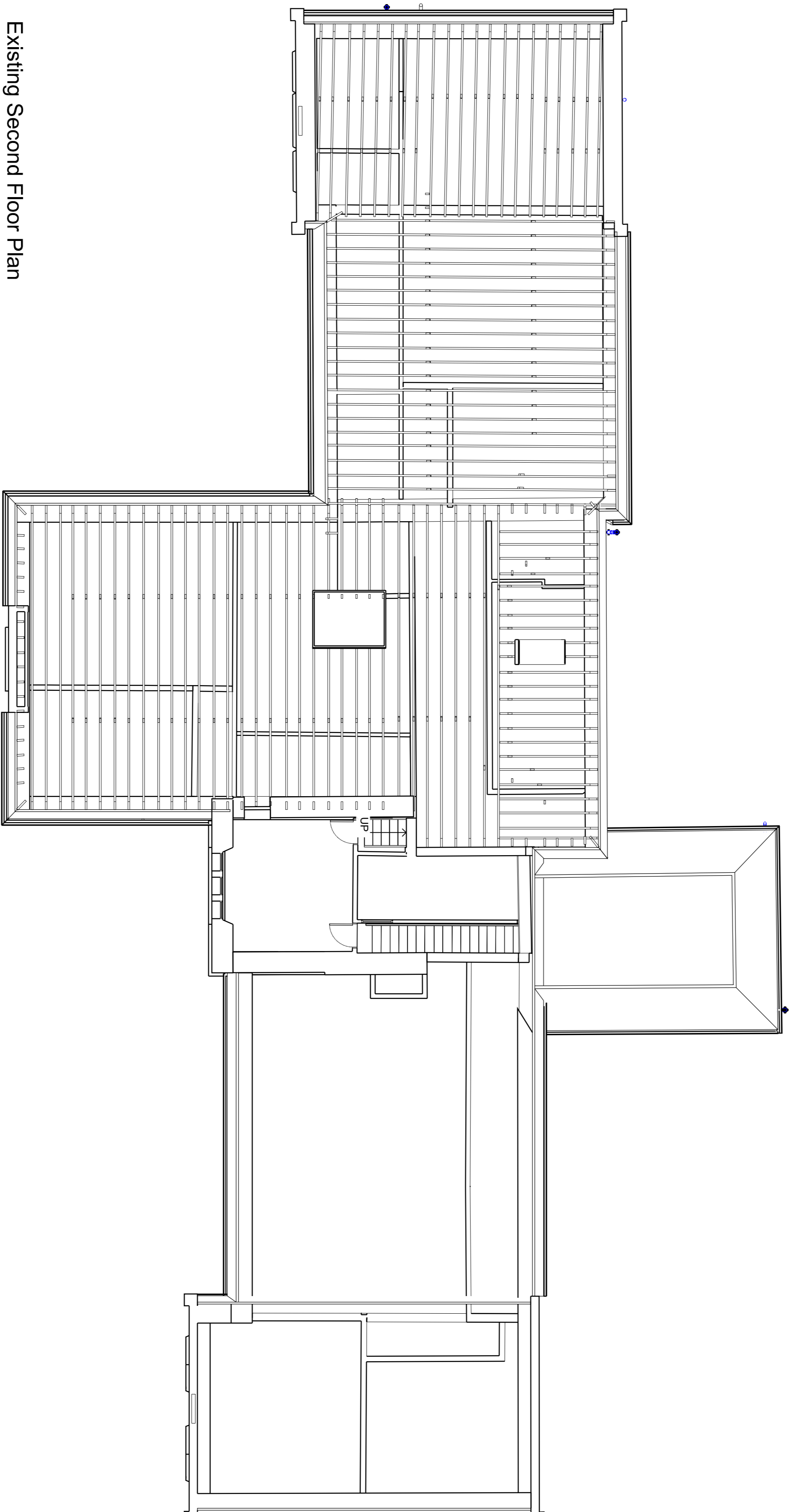

Existing Second Floor Plan

NOTES

DO NOT SCALE

Dimensions printed from pdf files must be checked against scale bar for accuracy.
 The Contractor must check & verify all sizes & locations of openings, levels & levels before starting work.
 The Drawing must be read with the RIBS Contract Specification and any amendments to it.
 The Drawing must be read with the RIBS Contract Specification and any amendments to it.
 The Drawing must be read with the RIBS Contract Specification and any amendments to it.
 The Drawing must be read with the RIBS Contract Specification and any amendments to it.

INFORMATION

Country: St Regeneration

Whalley Group

Existing Second Floor	
1250	AL(0)102
1:100	A1
CW	25/04/18

anderson bell + christie
 architects
 362 Great Western Road
 Glasgow G4 8RT
 T: +44 (0)141 339 1515
 F: +44 (0)141 339 0505
 Email: info@andersonbellchristie.com
 W: www.andersonbellchristie.com